

Miller DuraSeal™ Sealed Self- Retracting Lifeline



TECHNICAL DATA

SP508 Rev B/03-16

Description

The patent-pending Miller DuraSeal™ Self-Retracting Lifeline (SRL) is designed to perform in the harshest environments including on-shore and offshore oil and gas, mining and petrochemical applications. The DuraSeal's sealed technology, reusable brake system, field replaceable lifeline and corrosion resistant materials keep the product in the field to lower cost of ownership.

Materials

Housing: Cast Aluminum
Cable: Stainless Steel or Galvanized Steel
3/16 in. (5mm)

Technical

Max. Capacity: 420 lbs. (190.5 kg)
(when tested to OSHA 1926.502)

ANSI/CSA

Capacity Range: 130-310 lbs. (59-140.6 kg)

Max. Working Length: 50 ft. (15 m), 100 ft. (30 m),
130 ft. (40 m), 175 ft. (53 m)

Max. Total Arrest Distance:

SSRL50: 42 in. (1.1 m)
SSRL100, SSRL130, SSRL 175: 54 in. (1.4 m)

Max. Fall Arrest Force: 1,800 lbf. (8 kN)

Max./Avg. Fall Arrest Force: 1,800 lbf. (8 kN) / 900 lbf. (4 kN)
(when tested to ANSI Z359.14)

Ultimate Strength: 3,000 lbs. (13.34 kN)

Certification

Meets all OSHA 1926.502, 1910.66; ANSI Z359.14 Class B, A10.32; and CSA Z259.2.2 requirements, as well as:

- IEC 60529: International Protection Rating/Ingress Protection Ratings - IP68, Protected from total ingress. Dust tight and protected against 1m immersion in water.
- ISO 20653: Road vehicles - Degrees of protection (IP code) - IP69K, Protected from total ingress. Dust tight and protected against high pressure, steam-jet cleaning.

Connecting components meet or exceed ANSI Z359.12-2009 and CSA Z259.12-11 requirements for 3,600 lb. gate strength.



SSRL130S2



SSRL50S1

ATTACHING WITH CARABINER

ATTACHING WITH 4-BOLT HOLE PATTERN

MODEL	LENGTH	LIFELINE MATERIAL	WEIGHT	DIMENSIONS		
				LENGTH	WIDTH	DEPTH
Miller DuraSeal™ Sealed SRL with cable sling, tagline and 2 carabiners						
SSRL50S1	50 ft (15 m)	Stainless Steel	27.3 lb. (12 kg)	12.8 in. (325 mm)	11.8 in. (300 mm)	4.9 in. (125 mm)
SSRL100S1	100 ft (30 m)	Stainless Steel	59.7 lb. (27 kg)	15.7 in. (399 mm)	14.4 in. (366 mm)	6.6 in. (168 mm)
SSRL130S1	130 ft (40 m)	Stainless Steel	61.7 lb. (28 kg)	15.7 in. (399 mm)	14.4 in. (366 mm)	6.6 in. (168 mm)
SSRL175S1	175 ft (53 m)	Stainless Steel	76.5 lb. (35 kg)	15.7 in. (399 mm)	14.4 in. (366 mm)	7.8 in. (198 mm)
Miller DuraSeal™ Sealed SRL with cable sling, tagline, 2 carabiners and 4-hole mounting plate						
SSRL100G2	100 ft (30 m)	Galvanized Steel	61 lb. (28 kg)	15.7 in. (399 mm)	14.4 in. (366 mm)	6.6 in. (168 mm)
SSRL100S2	100 ft (30 m)	Stainless Steel	61 lb. (28 kg)	15.7 in. (399 mm)	14.4 in. (366 mm)	6.6 in. (168 mm)
SSRL130G2	130 ft (40 m)	Galvanized Steel	63 lb. (29 kg)	15.7 in. (399 mm)	14.4 in. (366 mm)	6.6 in. (168 mm)

DuraSeal™ SRL

Plate Mounting

For DuraSeal SRLs with the built-in mounting plate, install mounting plate to the anchorage or mounting surface using the required hardware as stated and the configuration shown.

Required hardware:

- Four (4) bolts, ½ in. (12 mm), minimum tensile strength 75 KSI (517 MPa)
- Four (4) washers, ½ in. (12 mm)
- Four (4) hex lock nuts, ½ in. (12 mm)

Always use approved hardware for installation.

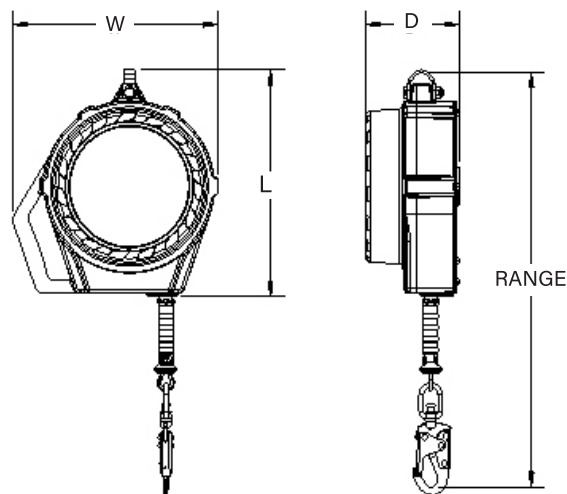

See table above for dimensions

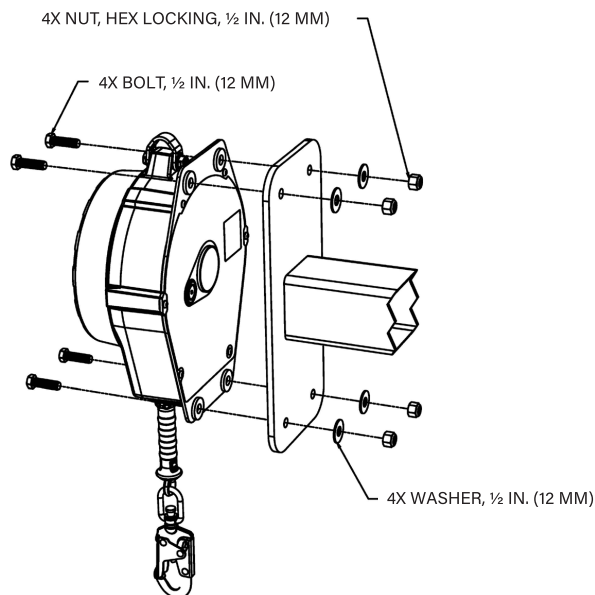
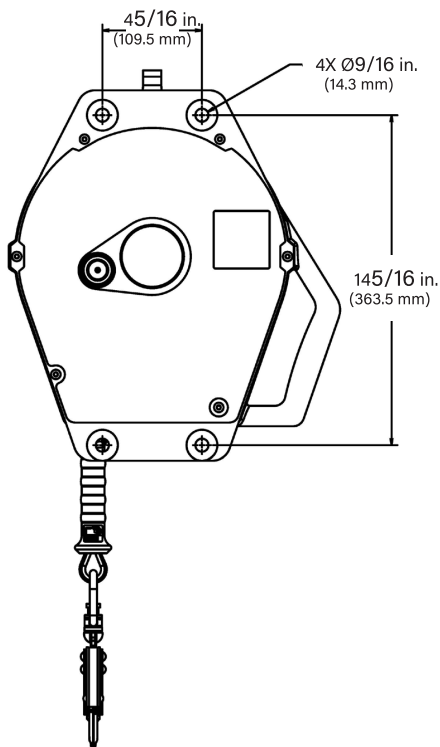

Model Number	Description	Weight
Miller Rapid Replace Lifeline Kits (<i>Kits include the cable assembly, a rubber plug, two shoulder screws, two entry guide screws, and two RFID clips.</i>)		
SSRL50SRR	50 ft (15 m) Stainless Steel Replacement Cable Kit	4.8 lbs. (2.2 kg)
SSRL130GRR	130 ft (40 m) Galvanized Replacement Cable Kit	9.9 lbs. (4.5 kg)
SSRL130SRR	130 ft (40 m) Stainless Steel Replacement Cable Kit	



Miller Rapid Replace Lifeline Kit

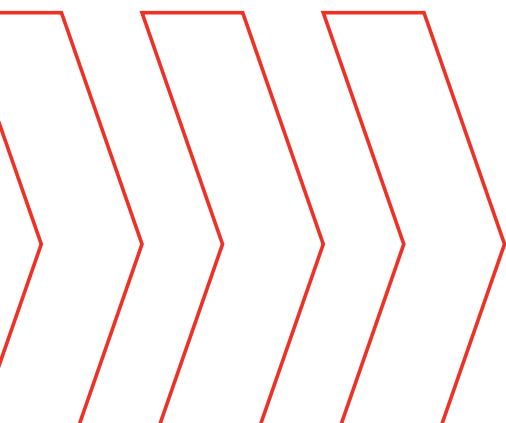

DuraSeal™ Accessory Products

SSRLTRK - 4 ft. (1.2 m) Cable Sling (Anchorage Tether) with 3/8 in. (9.5 mm) stainless steel wire rope and two zinc-plated steel O-rings.

Certifications: Cable Sling meets all OSHA 1910.66 (420 lbs.), OSHA 1926.502 (420 lbs.), ANSI Z359.1, ANSI A10.32 and ASTM 48 hour salt spray requirements.

Weight: 3.8 lbs. (1.7 kg)
Max. Capacity: 420 lbs. (190.5 kg), including body weight, clothing and tools. For use by ONE person only. Do not exceed this weight.



SSRLC - Stainless steel double locking carabiner with provision for an optional captive pin.

Weight: 0.47 lbs. (0.21 kg)

17D-1/ - Plated steel double locking carabiner with provision for an optional captive pin.

Weight: 0.5 lbs. (0.22 kg)

Certifications: Both carabiners meet ANSI Z359.12, CSA Z259.12, and EN362:2004/B requirements and ASTM 48 hour salt spray requirements.

Connecting components meet or exceed ANSI Z359.12-2009 or CSA Z259.12-11 requirements for 3,600 lb gate strength.

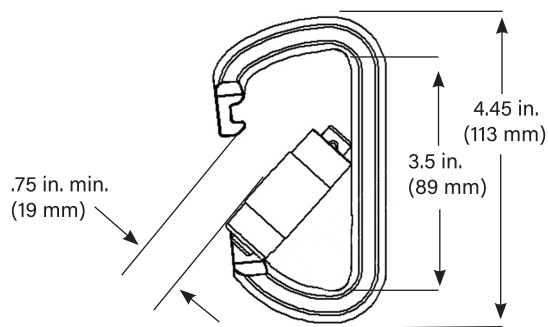

SSRLC

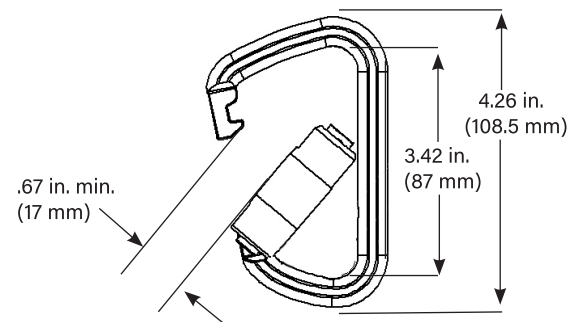

17D-1/



AUSTRALIA AND NEW ZEALAND
 For More Information
www.pipglobalsafety.com | Contact us

